

S100 LASER USB Mouse for Notebooks

QUICK GUIDE

FCC Statement

This device complies with part 15 of FCC Rules. Operation is subject to the following two conditions:
(1) this device may not cause harmful interference, and (2) this device must accept any interference received, including interference that may cause undesired operation.

This equipment has been tested and found to comply with the limits for a Class B digital device, pursuant to part 15 of the FCC Rules. These limits are designed to provide reasonable protection against harmful interference in a residential installation. This equipment generates uses and can radiate radio frequency energy and, if not installed and used in accordance with the instructions, may cause harmful interference to radio communications. However, there is no guarantee that interference will not occur in a particular installation. If this equipment does cause harmful interference to radio or television reception, which can be determined by turning the equipment off and on, the user is encouraged to try to correct the interference by one or more of the following measures:
- Reorient or relocate the receiving antenna.
- Increase the separation between the equipment and the receiver.
- Connect the equipment into an outlet on a circuit different from that to which the receiver is connected.



Designed by Icon 7 Inc.
Made in China

RSVP Your Icon7 Style Now!

Thank you for your interest and purchase of an Icon7 product!
Your enjoyment and satisfaction with our product(s) are our greatest achievements, and to better serve you, we cordially invite you to register your Icon7 product online at: www.icon7.com/support.aspx

Please go to the link above to register and receive Icon7's latest news, product, software and driver updates, plus other fun-filled offerings...
So, don't wait and REGISTER TODAY!

* For complete information about Icon7's Privacy Policy, please visit us at www.icon7.com

Icon 7 Inc. 3-Year Limited Warranty Information

Thank you for your purchase of our product! Icon 7 Inc. ("Icon7") warrants your Icon7 hardware product against defects in material and workmanship under normal conditions of use and service for three years beginning from your original date of purchase. Please retain your original dated sales receipt as proof of the date of purchase. You will need it and might be requested to show the receipt for your warranty service. In addition, this warranty is limited to the original purchaser and is non-transferable. Under this warranty, Icon7, at its discretion, shall repair or replace the defective device.

For this warranty to be in effect, by normal conditions of use, the product should be used and handled as outlined in the instructions accompanying the product. Icon7 does not cover any damage due to accident, negligence or misuse of the product. This warranty is only valid if the product is used on the required systems as outlined on the packaging. Please check the product box or user's manual for further details and instructions. Any other inquiry, please e-mail: support@icon7.com. Repair or replacement, as indicated in this warranty, is at the discretion of Icon7. Icon7 shall not be responsible or liable for any incidental damages. Some territories/countries do not allow limitations on how long a warranty lasts, so the above limitation may not apply to your particular territory/country.

S100 Laser USB Mouse for Notebooks

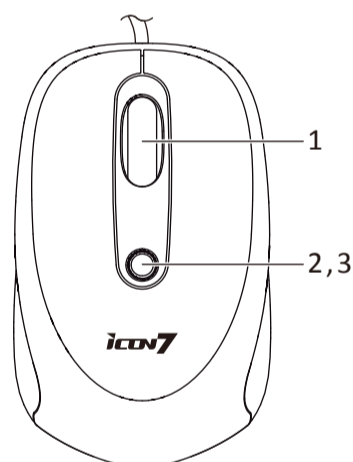
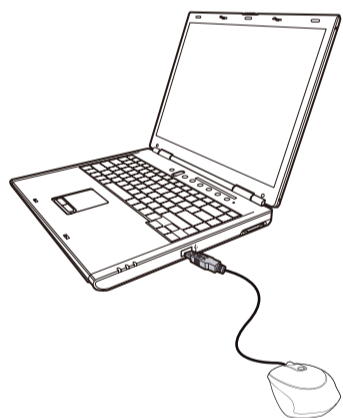

EN 1. 4-way Scrolling

- Top Button
 - Holding for 3 sec. for DPI Setting switch
 - Single Click for Application Switch
 - Double Click for Flip 3D
- DPI Indicator
 - Blinking orange : 800 dpi
 - Orange : 1200 dpi
 - Blue : 1600 dpi

SP 1. Desplazamiento en 4 direcciones

- Botón superior
 - Manténgalo presionado durante 3 segundos para cambiar a la configuración DPI.
 - Haga clic con él para cambiar de aplicación.
 - Haga doble clic con él para pasar a Flip 3D.
- Indicador DPI
 - Ilumina en color naranja : 800 ppp
 - Naranja : 1200 ppp
 - Azul : 1600 ppp

PT 1. Rolagem de quatro direções

- Botão superior
 - Segurando por 3 segundos para alternar a configuração de DPI
 - Um clique para alternar o aplicativo
 - Duplo clique para Flip 3D
- Indicador de DPI
 - Piscando em laranja : 800 dpi
 - Laranja : 1200 dpi
 - Azul : 1600 dpi

IT 1. Scorrimento a 4 vie

- Tasto superiore
 - Tenere premuto per 3 sec. l'interruttore Impostazione DPI
 - Fare un solo clic per l'interruttore dell'applicazione
 - Fare doppio clic per Flip 3D
- Indicatore DPI
 - Arancione lampeggiante : 800 dpi
 - Arancione : 1200 dpi
 - Blu : 1600 dpi

DE 1. 4-Wege-Scrollen

- Obere Maustaste
 - DPI-Wahlschalter ca. 3 Sekunden lang gedrückt halten
 - Einfachklick für Anwendungsschalter
 - Doppelklick für Flip 3D
- DPI-Anzeige
 - Orange leuchtet : 800 dpi
 - Orange : 1200 dpi
 - Blau : 1600 dpi

RU 1. 4-сторонняя прокрутка

- Верхняя кнопка
 - Удерживайте в течение 3-х секунд для смены настроек разрешения
 - Один щелчок для смены приложений
 - Двойной щелчок для запуска функции Flip 3D
- Индикатор разрешения
 - Оранжевым цветом : 800 dpi
 - Оранжевый : 1200 dpi
 - Голубым : 1600 dpi

FR 1. Déroulement quadri-directionnel

- Bouton du haut
 - Appuyez pendant 3 sec. pour la commutation en paramétrage DPI
 - Un seul clic pour la commutation Application
 - Double-cliquez pour Flip 3D
- Voyant DPI
 - Orange et clignote : 800 ppp
 - Orange : 1200 ppp
 - Bleu : 1600 ppp

CZ 1. 4směrné procházení

- Horní tlačítka
 - Stisknutí a podržení o dobu 3 sekund: přepínač DPI Setting (Nastavení DPI)
 - Klepnutí: Application Switch (Přepínač aplikací)
 - Poklepání: Flip 3D (Překlopit 3D)
- Indikátor DPI
 - Bliká oranžově : 800 dpi
 - Oranžová : 1200 dpi
 - Modrá : 1600 dpi

SK 1. Rolovanie v 4 smeroch

- Horné tlačidlo
 - Podržte počas doby 3 sekúnd, čím dôjde k zapnutiu nastavenia DPI
 - Jedným kliknutím prepnete aplikáciu
 - Dvojitým kliknutím zapnete otočenie 3D
- Indikátor DPI
 - Bliká na oranžovo : 800 dpi
 - Oranžová : 1200 dpi
 - Modrý : 1600 dpi

HU 1. Négyirányú görgetőgomb

- Felső gomb
 - Tartsa lenyomva 3 másodpercig a DPI beállítás váltásához
 - Egy kattintás az alkalmazások közötti váltáshoz
 - Dupla kattintás a Flip 3D funkcióhoz
- DPI kijelző
 - Narancssárga fényel villog : 800 dpi
 - Narancssárga : 1200 dpi
 - Kék : 1600 dpi

SL 1. 4-smerno drsenje

- Zgornji gumb
 - Držanje 3 s. za preklon DPI nastavitve
 - Enojni klik za preklon aplikacije
 - Dvojni klik za Obrni 3D
- DPI indikator
 - Eutripa oranžno : 800 dpi
 - Oranžna : 1200 dpi
 - Modra : 1600 dpi

RO 1. Defilare în 4 sensuri

- Buton superior
 - Mențineți apăsat timp de 3 sec. pentru comutare Setare DPI
 - Faceți un singur clic pentru comutare aplicație
 - Faceți dublu clic pentru Răsturnare 3D
- Indicator DPI
 - portocaliu intermitent : 800 dpi
 - Portocaliu : 1200 dpi
 - Albastru : 1600 dpi

PL 1. 4-kierunkowe przewijanie

- Górny guzik
 - Przytrzymanie przez 3 sek. przełącza przełącznik ustawień DPI
 - Pojedyncze kliknięcie przełącza aplikacje
 - Dwukrotne kliknięcie włącza funkcję Flip 3D
- Wskaźnik DPI
 - Migając w kolore pomarańczowym : 800 dpi
 - Pomarańczowy : 1200 dpi
 - Niebieski : 1600 dpi

AR

- تنقل رباعي الاتجاه
- الزر العلوي
 - اضغط مع الاستمرار لمدة 3 ثوان لتبديل إعداد DPI
 - انقر مرة واحدة لتبديل التطبيق
 - انقر نقراً مزدوجاً لتشغيل وظيفة Flip 3D
- مؤشر DPI
 - بهرتقالي وامض: 800 نقطة في البوصة
 - بهرتقالي: 1200 نقطة في البوصة
 - أزرق: 1600 نقطة في البوصة

EN To view the complete User's Manual and/or to install the driver, please refer to either the CD-ROM enclosed in the package, or go online to: www.icon7.com/support.aspx

SP Para visualizar el Manual de usuario completo y/o instalar el controlador, consulte el CD-ROM incluido en el embalaje o diríjase a: www.icon7.com/support.aspx

PT Para ver o Manual do usuário completo e/ou para instalar o driver, consulte o CD-ROM que acompanha o produto, ou visite: www.icon7.com/support.aspx

DE Um die gesamte Bedienungsanleitung zu lesen und/oder den Treiber zu installieren, sehen Sie bitte auf der mitgelieferten CD-ROM nach oder im Internet unter: www.icon7.com/support.aspx

FR Pour voir le Mode d'emploi complet et/ou pour installer le pilote, veuillez consulter le CD-ROM fourni dans le paquet, ou allez sur le site web: www.icon7.com/support.aspx

IT Per visualizzare per intero il manuale dell'utente e/o installare il driver, consultare il CD-ROM in dotazione o visitare online il sito: www.icon7.com/support.aspx

RU Для просмотра полного руководства пользователя и (или) установки драйвера см. либо входящий в комплект поставки компакт-диск, либо перейдите на веб-сайт: www.icon7.com/support.aspx

CZ Pokyny pro zobrazení celé uživatelské příručky a/nebo pro instalaci ovládače najdete na disku CD-ROM přiloženém v krabici nebo online na: www.icon7.com/support.aspx

SK Pre prezretie kompletného návodu na obsluhu a/alebo inštaláciu ovládača si pozrite buď CD-ROM priložený v balení, alebo navštívte internetovú stránku: www.icon7.com/support.aspx

SL Za ogled celotnega Prilogočnika za uporabo in/ali namestitve gonilnika, prosimo uporabite priloženi CD, ali pojdite na: www.icon7.com/support.aspx

PL W celu wyświetlenia całego podręcznika użytkownika i/lub instalacji sterownika należy odszukać w opakowaniu dysk CD-ROM lub przejść online pod adres: www.icon7.com/support.aspx

HU A teljes felhasználói kézikönyv megtekintéséhez és/vagy az illesztőprogram telepítéséhez tekintse meg a csomagban mellékelt CD-ROM-ot, vagy látogassa meg a weboldalt: www.icon7.com/support.aspx

RO Pentru a vedea Manualul de utilizare complet și/sau pentru a instala driverul, consultați CD-ROM-ul inclus în pachet sau accesați online: www.icon7.com/support.aspx

AR لعرض دليل المستخدم أملاً و/أو تثبيت برنامج التشغيل، يرجى الرجوع إلى القرص المدمج المرفق بالعبوة أو زيارة الموقع الإلكتروني: www.icon7.com/support.aspx

S100 Laser USB Mouse for Notebooks

